

01215

**MRD1400HZ16
Camera Control
Interface for the
CC1400HZ16**

**Installation/
Operation Manual**

C1973M-B (8/03)

CONTENTS

Section	Page
IMPORTANT SAFEGUARDS AND WARNINGS	3
DESCRIPTION	4
INSTALLATION	4
DIP SWITCH SETTINGS	4
BAUD RATE SELECTION	4
MRD ADDRESS SETTINGS	5
MRD1400HZ16 INSTALLATION METHODS	6
WALL MOUNTING	6
DF5/DF8 SERIES DOME INSTALLATION	6
EH3512 SERIES ENCLOSURE INSTALLATION	8
EH2512 SERIES ENCLOSURE INSTALLATION	9
CONTROL, POWER, AND CAMERA CONNECTIONS	10
OPERATION	11
TROUBLESHOOTING	12
WARRANTY AND RETURN INFORMATION	12

LIST OF ILLUSTRATIONS

Figure	Page
1 SW-1 Default Switch Settings	4
2 Wall Mounting	6
3 DF5/DF8 Installation	7
4 Removing the MRD Board	7
5 Installing the EH3512 Adapter	8
6 Installing the MRD Board onto the EH3512 Adapter	8
7 EH2512 Series Enclosure Installation	9
8 Control, Power, and Camera Connections	10
9 Multiple Units with Parallel Connections	10
10 Data Cable Wiring	10

LIST OF TABLES

Table	Page
A Baud Rate Switch Settings	4
B MRD DIP Switch Settings	5
C Two-Wire Control Connections	10

IMPORTANT SAFEGUARDS AND WARNINGS

Prior to installation and use of this product, the following WARNINGS should be observed.

1. Installation and servicing should only be done by qualified service personnel and conform to all local codes.
2. There are no user-serviceable parts inside this unit. Only authorized service personnel may open the unit.
3. To reduce the risk of fire or electric shock, do not expose this unit to rain or moisture if this unit is designed for indoor use only.

The product and/or manual may bear the following marks:



This symbol indicates that dangerous voltage constituting a risk of electric shock is present within this unit.



This symbol indicates that there are important operating and maintenance instructions in the literature accompanying this unit.

CAUTION:
RISK OF ELECTRIC SHOCK. DO NOT OPEN.

Please thoroughly familiarize yourself with the information in this manual prior to installation and operation.

DESCRIPTION

The MRD1400HZ16 is a camera interface control for Pelco's CC1400HZ16 Series digital color camera. The unit can be mounted directly to a wall or installed in a DF5 Series dome, DF8A Series dome, EH2512 Series enclosure, or EH3512 Series enclosure.

The MRD1400HZ16 can be used with the following Pelco controllers and matrix switchers:

Controllers (direct mode only)	MPT9500, CM9760-KBD Series, KBD200A, and KBD300A
Matrix Switchers (configured for D or P protocols only)	CM6700 Series, CM6800 Series, CM9740 Series, and CM9760 Series

INSTALLATION

The following items are supplied:

Qty.	Item
1	MRD1400HZ16
1	DF5/DF8/EH2512 Series adapter
1	EH3500 Series adapter
1	4-pin connector
1	Data cable (12 inches)
4	4-40 Phillips button head screws
1	#10 nut and washer
1	Camera sled for EH3500 Series enclosure

DIP SWITCH SETTINGS

NOTE: *Baud/Address Settings – If switch settings are changed while the power to the MRD unit is ON, push and hold the reset button for five seconds and then release, to recycle power and accept the new baud/address setting. Refer to Figure 4 for the location of the reset button.*

BAUD RATE SELECTION

The baud rate must be set for the MRD1400HZ16 to automatically sense D or P protocol. The default communication rate for the MRD1400HZ16 is 4800 baud. If the system's controller/switcher uses a different communication rate, change the baud rate of the MRD1400HZ16 to match the controller/switcher.

To change the baud rate, refer to Figure 1 and Table A.

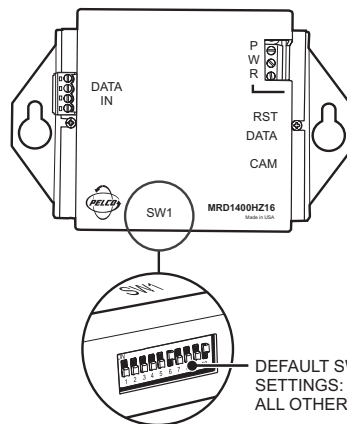

Table A. Baud Rate Switch Settings

Baud Rate	Switch Setting	
	6	7
2400	OFF	OFF
4800	ON	OFF
9600	OFF	ON

NOTE: *Dip switches 8, 9, and 10 are factory set. Do not change switch positions.*

DEFAULT SWITCH SETTINGS: 6 & 10 ON
ALL OTHER SWITCHES OFF

01218

Figure 1. SW-1 Default Switch Settings

MRD ADDRESS SETTINGS

A camera address setting is required for the controller/switcher to communicate with the MRD1400HZ16. The default setting for the MRD is Receiver Address 1. If you are using more than one MRD, each unit must have a different Receiver Address.

To change the address setting of the MRD, refer to Figure 1 and Table B.

Table B. MRD DIP Switch Settings

Receiver Address	MRD DIP Switch Setting				
	1	2	3	4	5
1	Off	Off	Off	Off	Off
2	On	Off	Off	Off	Off
3	Off	On	Off	Off	Off
4	On	On	Off	Off	Off
5	Off	Off	On	Off	Off
6	On	Off	On	Off	Off
7	Off	On	On	Off	Off
8	On	On	On	Off	Off
9	Off	Off	Off	On	Off
10	On	Off	Off	On	Off
11	Off	On	Off	On	Off
12	On	On	Off	On	Off
13	Off	Off	On	On	Off
14	On	Off	On	On	Off
15	Off	On	On	On	Off
16	On	On	On	On	Off
17	Off	Off	Off	Off	On
18	On	Off	Off	Off	On
19	Off	On	Off	Off	On
20	On	On	Off	Off	On
21	Off	Off	On	Off	On
22	On	Off	On	Off	On
23	Off	On	On	Off	On
24	On	On	On	Off	On
25	Off	Off	Off	On	On
26	On	Off	Off	On	On
27	Off	On	Off	On	On
28	On	On	Off	On	On
29	Off	Off	On	On	On
30	On	Off	On	On	On
31	Off	On	On	On	On
32	On	On	On	On	On

MRD1400HZ16 INSTALLATION METHODS

There are three methods of installation for the MRD1400HZ16. The unit can be mounted directly to a wall, or installed inside a dome or enclosure using the supplied mount adapters. Refer to the following sections and select the correct installation method for your application.

WALL MOUNTING

To mount the MRD1400HZ16 directly to a wall, refer to Figure 2 and do the following:

1. Select the mounting location. Install the unit close to the camera.
2. Use the MRD1400HZ16 as a template to mark the two fastener positions onto the mounting surface.
3. Prepare the surface and install the fasteners. Do not tighten fasteners at this time.
4. Align the mounting holes of the MRD1400HZ16 with the installed wall fasteners.
5. Place the unit over the fasteners, and then slide the box down into position. Tighten the fasteners to secure the unit to the wall.
6. Make all required control, power, and camera connections. Refer to Figure 8 and the *Control, Power, and Camera Connections* section of this manual.

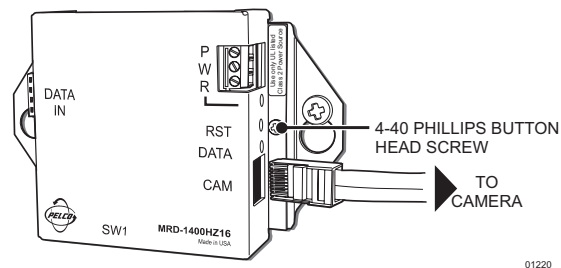
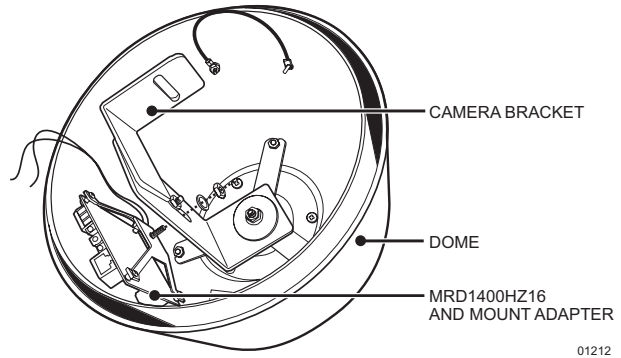

Figure 2. Wall Mounting

DF5/DF8 SERIES DOME INSTALLATION

To install the MRD1400HZ16 in a DF5/DF8 dome:

1. Remove the MRD board from the MRD1400HZ16. To remove the board:
 - a. Unscrew the two Phillips button head screws from the unit (refer to Figure 2), and remove the cover. Discard the screws.
 - b. Using a small screwdriver, carefully pry each corner of the board from the PEM studs. Refer to Figure 4.
2. Use the four 4-40 Phillips button head screws (provided) to attach the board to the DF5/DF8/EH2512 Series adapter.
3. Assemble the tilt table supplied with the dome. For detailed instructions refer to the manual supplied with the DF5/DF8 Series dome.
4. Refer to Figure 3. Attach the board to the tilt table with the supplied #10 nut and washer.
5. Make all required control, power, and camera connections. Refer to Figure 8 and the *Control, Power, and Camera Connections* section of this manual.
6. Refer to the manual supplied with the DF5 or DF8 Series dome to install the camera and complete the installation.



01212

Figure 3. DF5/DF8 Installation

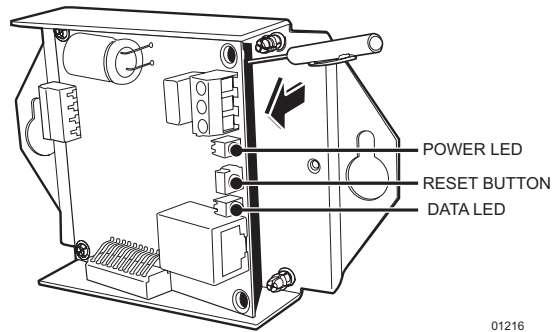

01216

Figure 4. Removing the MRD Board

EH3512 SERIES ENCLOSURE INSTALLATION

Do the following to install the MRD1400HZ16 in an EH3512 Series enclosure:

1. Remove the camera sled from the EH3512 Series enclosure. If the camera is attached to the sled remove the camera.
2. Attach the camera to the 4-inch camera sled supplied with the MRD. Install the camera sled and camera into the enclosure. Place the camera sled as close to the viewing window as possible.
3. Remove the PC board from the MRD1400HZ16. To remove the board:
 - a. Unscrew the two Phillips button head screws from the unit (refer to Figure 2), and remove the cover.
 - b. Using a small screwdriver, carefully pry each corner of the board from the PEM studs. Refer to Figure 4.
4. Refer to Figure 5. Install the EH3512 adapter into the enclosure.
5. Make all required control, power, and camera connections to the board. Refer to Figure 8 and the *Control, Power and Camera Connections* section of this manual.
6. Refer to Figure 6. Position the board over the EH3512 adapter. The DIP switches of the board should face up. Lightly press on each corner of the board to attach it to the PEM studs of the adapter.

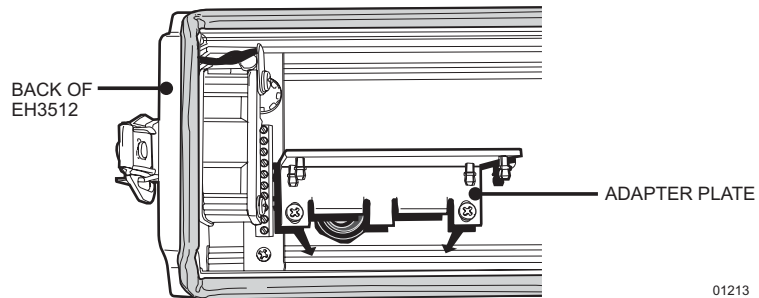

Figure 5. Installing the EH3512 Adapter

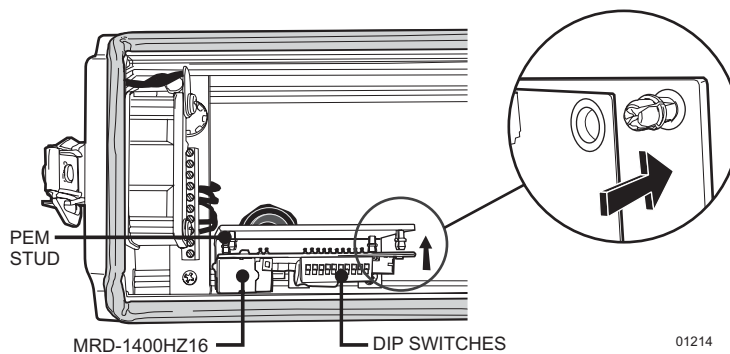

Figure 6. Installing the MRD Board onto the EH3512 Adapter

EH2512 SERIES ENCLOSURE INSTALLATION

To install the MRD1400HZ16 in an EH2512 Series enclosure:

1. Remove the PC board from the MRD1400HZ16. To remove the board:
 - a. Unscrew the two Phillips button head screws from the unit (refer to Figure 2), and remove the cover. Discard the screws.
 - b. Using a small screwdriver, carefully pry each corner of the board from the PEM studs. Refer to Figure 4.
2. Use the four 4-40 Phillips button head screws (provided) to attach the board to the DF5/DF8/EH2512 Series adapter.
3. Remove the camera sled from the housing. Refer to the manual supplied with the EH2512 Series enclosure.
4. Make all required control, power, and camera connections. Refer to Figure 8 and the *Control, Power, and Camera Connections* section of this manual.
5. Refer to Figure 7. Attach the board to the camera sled of the enclosure with the supplied #10 nut and washer.
6. Refer to the manual supplied with the EH2512 Series enclosure to install the camera and complete the installation.

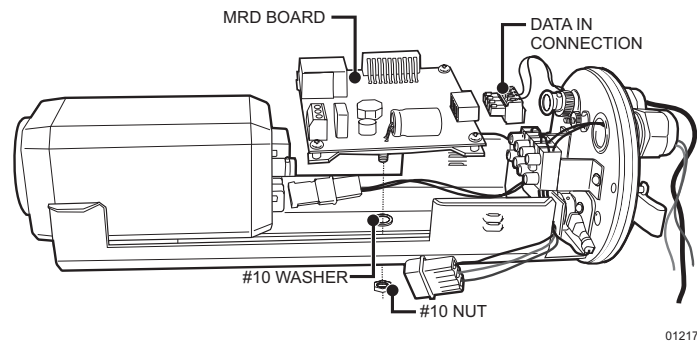

Figure 7. EH2512 Series Enclosure Installation

CONTROL, POWER, AND CAMERA CONNECTIONS

1. Refer to Figure 8 and Table C. Connect the control wires from the controller to the MRD DATA IN connector. Use the supplied four-pin connector. To connect multiple units with parallel connections refer to Figure 9.
2. Connect one end of the 12-inch data cable into the CAM input of the MRD (refer to Figure 8). Connect the other end of the cable to the camera connector labeled CONTROL OUT. If the installation requires a longer data cable refer to Figure 10. Maximum cable length is 25-feet.
3. Make required power connections. Refer to Figure 8.

Note: Input power range 12-24 volts AC/DC.

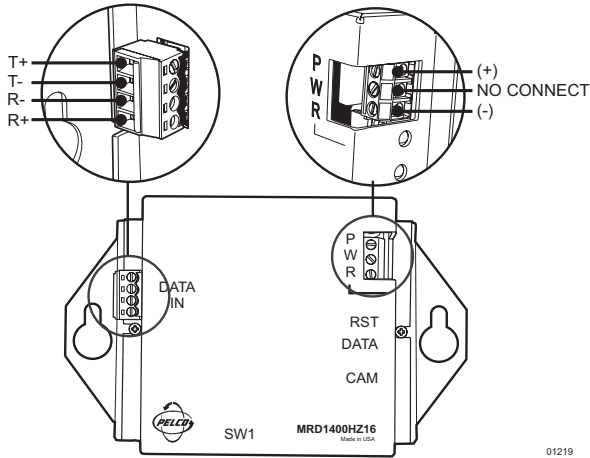

Table C. Two-Wire Control Connections

From Controller	MRD
TX+	R+
TX-	R-

Figure 8. Control, Power, and Camera Connections

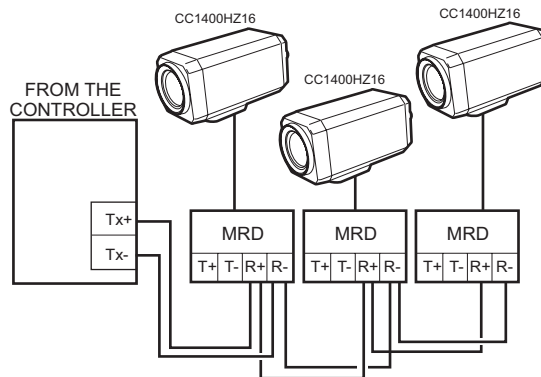

Figure 9. Multiple Units with Parallel Connections

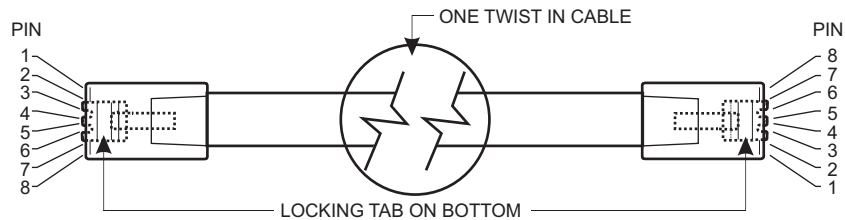

Figure 10. Data Cable Wiring

01221

OPERATION

CAMERA OPERATION	PELCO CONTROLLER COMMAND
Zoom In	Tilt joystick up
Zoom Out	Tilt joystick down
Quickly Zoom In	Press the Zoom Tele button or turn the joystick clockwise
Quickly Zoom Out	Press the Zoom Wide button or turn the joystick counterclockwise
Focus Near	Press the Focus Near button
Focus Far	Press the Focus Far button
Increase Brightness	Press the Iris Open button
Decrease Brightness	Press the Iris Close button
Enter/Exit the camera menu	*Preset 95 or AUX 8 ON
Navigate through the camera menu	Move the joystick up or down to move through menu selections
Increase the value of the selected menu item	Press the Focus Far button
Decrease the value of the selected menu item	Press the Focus Near button

PRESETS (Refer to the documentation supplied with the controller for instructions on how to set and call a preset.)

Save camera action as preset 1-8	1-8 Set
Move to preset position 1-8	1-8 Call
Clear control lockup if undefined preset is called	Preset 9 Call
Enter/Exit menu	*Preset 95 Call

AUX (Refer to the documentation supplied with the controller for instructions on auxiliary commands.)

Turn camera power on	Aux 1 on
Turn camera power off	Aux 1 off
Enable/Disable the three digit MRD address display	Aux 2 on
Turn digital zoom on	Aux 3 on
Turn digital zoom off	Aux 3 off
Reset the Camera	Aux 4 on
Display mirror image on screen; left-right flip (digital zoom must be enabled)	Aux 6 on
Display normal image on screen (digital zoom must be enabled)	Aux 6 off
Display current software version for 3 seconds	Aux 7 on
Enter/Exit menu	*Aux 8 on

*Subsequent operation must be performed before repeating command.

TROUBLESHOOTING

Problem	Possible Cause and Solutions
Unit does not operate. No power.	<ol style="list-style-type: none"> 1. Check to see if the power LED is lit. If the LED is not lit: <ol style="list-style-type: none"> a. Verify input power is good. b. Check power connections to make sure the wires are making contact. c. Verify the input power source is in range 12-24 volts AC/DC.
Camera does not respond or responds improperly to commands.	<ol style="list-style-type: none"> 1. Check the baud rate of the MRD and the controller/switcher. Both should have the same baud rate setting. 2. The camera address is not set correctly. Check the MRD camera address setting. 3. If the baud or address switch settings are changed, press the power reset button (see Figure 4).
Video erratic. Control lock up. Can not call preset.	<ol style="list-style-type: none"> 1. The selected preset has not been defined. To clear lock up: <ol style="list-style-type: none"> a. Call preset 9. b. Define new preset.
DATA LED is not lit.	<ol style="list-style-type: none"> 1. Check connection to the camera. 2. Push and hold the power reset button for 5 seconds and then release, to recycle power to the camera. Refer to Figure 4.

SPECIFICATIONS

MECHANICAL

Construction: Aluminum
 Dimensions: 3.30 (H) x 3.70 (W) x 1.12 (D) inches (8.38 x 9.40 x 2.84 cm)
 Electrical: 12-24 VAC/VDC (+10%/-15%), 50/60-HZ
 Power Consumption: <1 watt
 Communication: RS-422, half-duplex

(Design and product specifications subject to change without notice.)

PRODUCT WARRANTY AND RETURN INFORMATION

WARRANTY

Pelco will repair or replace, without charge, any merchandise proved defective in material or workmanship for a period of one year after the date of shipment.

Exceptions to this warranty are as noted below:

- Five years on FT/FR8000 Series fiber optic products.
- Three years on Genex® Series products (multiplexers, server, and keyboard).
- Three years on Camclosure® and fixed camera models, except the CC3701H-2, CC3701H-2X, CC3751H-2, CC3651H-2X, MC3651H-2, and MC3651H-2X camera models, which have a five-year warranty.
- Two years on standard motorized or fixed focal length lenses.
- Two years on Legacy®, CM6700/CM6800/CM9700 Series matrix, and DF5/DF8 Series fixed dome products.
- Two years on Spectra®, Esprit®, ExSite™, and PS20 scanners, including when used in continuous motion applications.
- Two years on Esprit® and WW5700 Series window wiper (excluding wiper blades).
- Eighteen months on DX Series digital video recorders, NVR300 Series network video recorders, and Endura™ Series distributed network-based video products.
- One year (except video heads) on video cassette recorders (VCRs). Video heads will be covered for a period of six months.
- Six months on all pan and tilts, scanners or preset lenses used in continuous motion applications (that is, preset scan, tour and auto scan modes).

Pelco will warrant all replacement parts and repairs for 90 days from the date of Pelco shipment. All goods requiring warranty repair shall be sent freight prepaid to Pelco, Clovis, California. Repairs made necessary by reason of misuse, alteration, normal wear, or accident are not covered under this warranty.

Pelco assumes no risk and shall be subject to no liability for damages or loss resulting from the specific use or application made of the Products. Pelco's liability for any claim, whether based on breach of contract, negligence, infringement of any rights of any party or product liability, relating to the Products shall not exceed the price paid by the Dealer to Pelco for such Products. In no event will Pelco be liable for any special, incidental or consequential damages (including loss of use, loss of profit and claims of third parties) however caused, whether by the negligence of Pelco or otherwise.

The above warranty provides the Dealer with specific legal rights. The Dealer may also have additional rights, which are subject to variation from state to state.

If a warranty repair is required, the Dealer must contact Pelco at (800) 289-9100 or (559) 292-1981 to obtain a Repair Authorization number (RA), and provide the following information:

1. Model and serial number
2. Date of shipment, P.O. number, Sales Order number, or Pelco invoice number
3. Details of the defect or problem

If there is a dispute regarding the warranty of a product which does not fall under the warranty conditions stated above, please include a written explanation with the product when returned.

Method of return shipment shall be the same or equal to the method by which the item was received by Pelco.

RETURNS

In order to expedite parts returned to the factory for repair or credit, please call the factory at (800) 289-9100 or (559) 292-1981 to obtain an authorization number (CA number if returned for credit, and RA number if returned for repair).

All merchandise returned for credit may be subject to a 20% restocking and refurbishing charge.

Goods returned for repair or credit should be clearly identified with the assigned CA or RA number and freight should be prepaid. Ship to the appropriate address below.

If you are located within the continental U.S., Alaska, Hawaii or Puerto Rico, send goods to:

Service Department
 Pelco
 3500 Pelco Way
 Clovis, CA 93612-5699

If you are located outside the continental U.S., Alaska, Hawaii or Puerto Rico and are instructed to return goods to the USA, you may do one of the following:

If the goods are to be sent by a COURIER SERVICE, send the goods to:

Pelco
 3500 Pelco Way
 Clovis, CA 93612-5699 USA

If the goods are to be sent by a FREIGHT FORWARDER, send the goods to:

Pelco c/o Expeditors
 473 Eccles Avenue
 South San Francisco, CA 94080 USA
 Phone: 650-737-1700
 Fax: 650-737-0933

REVISION HISTORY

Manual #	Date	Comments
C1973M	10/01	Original version.
C1973M-A	8/02	Revised instructions.
C1973M-B	8/03	Revised supplied parts list and installation instructions for DF5/DF8 and EH2512 enclosures.

Pelco, the Pelco logo, Camclosure, Esprit, Genex, Legacy, and Spectra are registered trademarks of Pelco. Endura and ExSite are trademarks of Pelco.

© Copyright 2003, Pelco
 All rights reserved.